



brands, inc.

M-1411 Foam Cooler

A safer and more cost effective way to ship

Our Insulated Shipping Containers (Foam Coolers) are designed to protect your perishables during transit. Whether you are shipping your products across town or across the country, our coolers will perform safely and effectively.

Each of our molded foam coolers is manufactured with Expanded Polystyrene (EPS) foam. EPS foam (AKA Styrofoam) is composed of 98% air and because the air that surrounds us is such a poor conductor, EPS foam is the perfect insulator. Our line of insulated boxes (Foam Coolers) can protect your perishables by maintaining an inside temperature that prevents spoilage. In addition, EPS is lightweight, strong, and offers superior cushioning for delicate products.

We manufacture coolers with different lengths, widths, depths and wall thicknesses, to accommodate the variable needs of our customers. Armstrong Brands is always adding new cooler sizes to its line of foam products. Let us help you design a Foam Cooler to meet your unique situation. Contact us today.

Corrugated shipping boxes are available to accommodate each cooler size.



Call 1-800-725-6415 or go to www.armstrongbrands.com



The foam & corrugated used in our packs are manufactured with completely recyclable and environmentally friendly materials.



Inside Dimensions:

13 3/4" Long X 10 3/4" Wide X 10" Deep

Outside Dimensions:

18" Long X 15" Wide X 14" Tall

Wall thickness = 2" (Top is 1" thick)

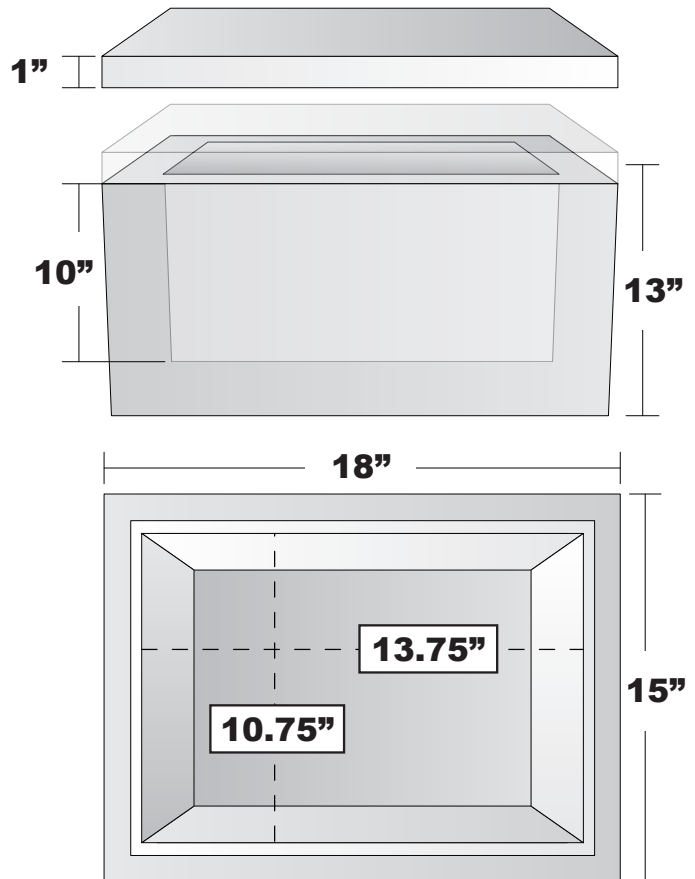

Inside dimensions listed are approximations of usable interior space.

